

SM46T



**SEMI-AUTOMATIC
TYRE-CHANGER FOR
TRUCK, BUS, AGRICULTURE
AND EARTH MOVING
VEHICLES 14"- 46"**



CEMB
GARAGE EQUIPMENT

SM46T

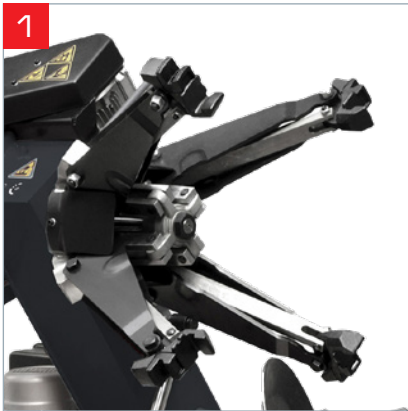

- Two rotation speed hydraulic chuck with 5 different rim locking positions
- Mandrino idraulico a due velocità di rotazione, con 5 differenti posizioni di bloccaggio del cerchio
- Mandrin hydraulique à deux vitesses de rotation avec 5 différentes positions de blocage
- Idraulisches Spannfutter mit zwei Drehgeschwindigkeiten und fünf verschiedenen Felgenspannstellungen
- Mandril hidráulico de dos velocidades con 5 diferentes posiciones de bloqueo de la llanta

- Portable control unit
- Comandi su consolle mobile
- Unité de contrôle portable
- Tragbare Steuereinheit
- Unidad de control movible



Universal electro-hydraulic tyre changer for truck, bus, agriculture and earth moving vehicles with a maximum diameter of 2.300mm and a maximum width of 1.065 mm.

Semi-automatic, with two speed hydraulic chuck and mobile control unit with anti-crush cable.



- Manual lifting and traversing of the tool-holder arm
- Sollevamento e rotazione manuali dell'utensile
- Soulèvement et mouvement de translation du bras porte outils obtenues manuellement
- Manuelles Anheben und Verschieben des Werkzeugarms
- Levantamiento y movimiento de traslación manuales del brazo porta-útiles



- Manual translational movement of the tool-holder carriage with two different working positions
- Traslazione manuale del braccio porta utensile con due posizioni di lavoro
- Translation manuelle du chariot porte-outils en deux positions de travail
- Manuelle Verschiebung des Werkzeugschlittens in zwei Arbeitspositionen
- Movimiento de traslación manual del carro porta-útiles en dos posiciones de trabajo



STANDARD EQUIPMENT



x 1



x 1



x 3

OPTIONAL ACCESSORIES



- Pliers for alloy rims
- Pinza per cerchi in lega
- Pince pour jantes en alliage
- Zange für Leichtlegierunsfelgen
- Tenaza para llantas en liga



- Jaw protections for alloy rims
- Serie di protezioni griffe per cerchi in lega
- Protections des griffes pour jantes en alliage
- Satz von Klauenschütze für Leichtlegierunsfelgen
- Juego de protecciones mordazas para llantas en liga



- Set of 4 extensions up to 56"
- Set di 4 prolunghe fino a 56"
- Set de 4 rallonges jusqu'à 56"
- Set mit 4 Verlängerungen bis 56"
- Juego de 4 extensiones hasta 56"

For more information see the complete brochure

TECHNICAL DATA

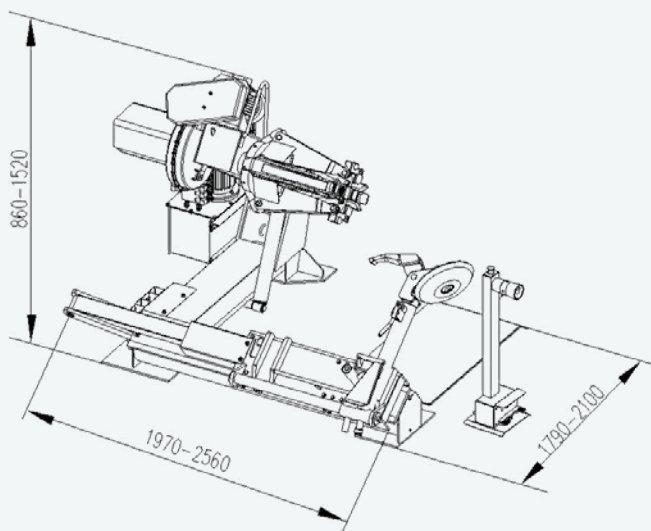

Clamping capacity	Capacità di bloccaggio	Pour roues de	Spannbereich	Rango de sugección	14" - 46" (56" w/extensions)
Max. wheel weight	Peso max. ruota	Poids maxi. roue	Radmaximalgewicht	Peso max. rueda	1500 Kg
Max. wheel width	Larghezza max. ruota	Largeur maxi. roue	Radbreite	Ancho max. rueda	1.065 mm (42")
Max. wheel diameter	Diámetro max. ruota	Diam. maxi. roue	Max. Raddurchmesser	Diámetro max. ruota	2.300 mm (90,5")
Hydraulic unit motor	Motore centralina	Moteur de la centrale	Aggregat-Motor	Motor unidad hidraulica	1.1 kW
Chuck motor	Motore mandrino	Moteur du mandrin	Spannfuttermotor	Motor mandrin	1,3 - 1,8 kW 400V/50Hz/3ph
Operating pressure	Pressione di servizio	Pression de Service	Betriebsdruck	Pression de servicio	0÷130 bar
Bead breaker force	Forza stallonatore	Force décolleur	Abdrückkraft	Foerza destalonador	2690 kgf
Gross weight	Peso lordo	Poids brut	Bruttogewicht	Peso bruto	816 kg
Packing dimensions	Dimensioni imballo	Dimensions emballage	Kistenabmessungen	Dimensiones emballaje	2020x1700x1020 h mm



CEMB

BALANCING MACHINES

CEMB S.p.A.

Via Risorgimento, 9
23826 Mandello del Lario (LC) - Italy
www.cemb.com



Garage equipment division
CEMB - ITALY
Plant and Training Center
Phone +39 0341 706111
garage@cemb.com

SIPAV

Distributore esclusivo per l'Italia:

Via A. Nobel, 21 - 42124 Sesso (RE)
Tel. 0522. 532.711 - Fax 0522.531.828
sipav@sipav.com - www.sipav.com

All the data and features mentioned in this catalogue are purely for information and do not constitute any commitment on the part of our company, which reserves the right to make any and all alterations it may consider suitable without notice.